

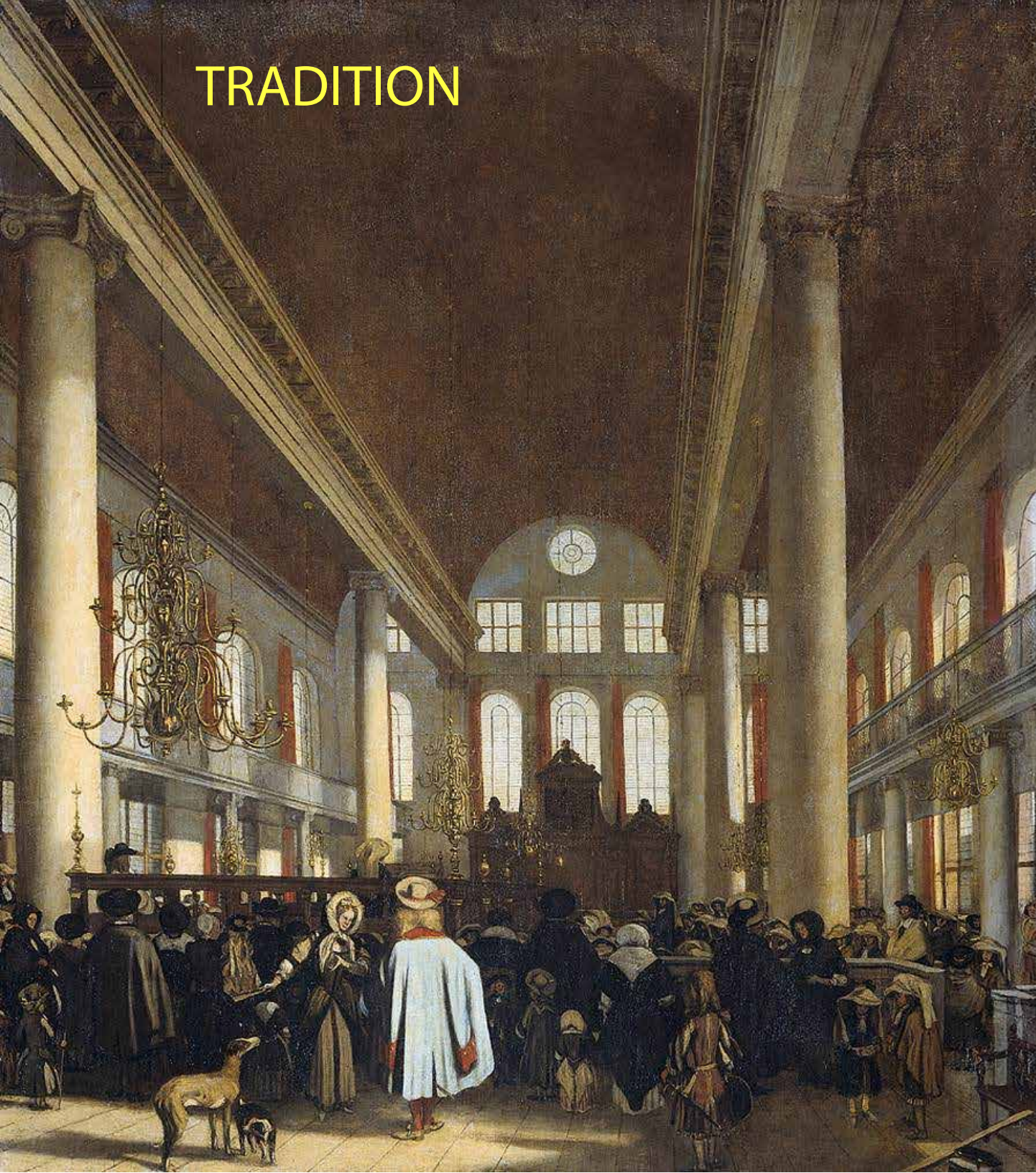
# SYNAGOGUE HET



ח

אבגדהו  
זחטיכל

TRADITION



TRADITION

**YOUR** SYNAGOGUE

MY SYNAGOGUE  
OUR SYNAGOGUE

**DRAFT**

*George Washington's Letter to the Hebrew Congregation  
in Newport, Rhode Island*

Gentlemen:

While I received with much satisfaction your address replete with expressions of esteem, I rejoice in the opportunity of assuring you that I shall always retain grateful remembrance of the cordial welcome I experienced on my visit to Newport from all classes of citizens.

The reflection on the days of difficulty and danger which are past is rendered the more sweet from a consciousness that they are succeeded by days of uncommon prosperity and security.

If we have wisdom to make the best use of the advantages with which we are now favored, we cannot fail, under the just administration of a good government, to become a great and happy people.

The citizens of the United States of America have a right to applaud themselves for having given to mankind examples of an enlarged and liberal policy—a policy worthy of imitation. All possess alike liberty of conscience and immunities of citizenship.

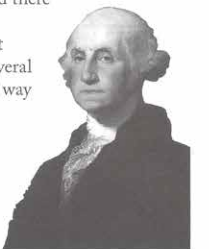
It is now no more that toleration is spoken of as if it were the indulgence of one class of people that another enjoyed the exercise of their inherent natural rights, for, happily, the Government of the United States, which gives to bigotry no sanction, to persecution no assistance, requires only that they who live under its protection should demean themselves as good citizens in giving it on all occasions their effectual support.

It would be inconsistent with the frankness of my character not to avow that I am pleased with your favorable opinion of my administration and fervent wishes for my felicity.

May the children of the stock of Abraham who dwell in this land continue to merit and enjoy the good will of the other inhabitants—while every one shall sit in safety under his own vine and fig tree and there shall be none to make him afraid.

May the father of all mercies scatter light, and not darkness, upon our paths, and make us all in our several vocations useful here, and in His own due time and way everlastingly happy.

*George Washington*



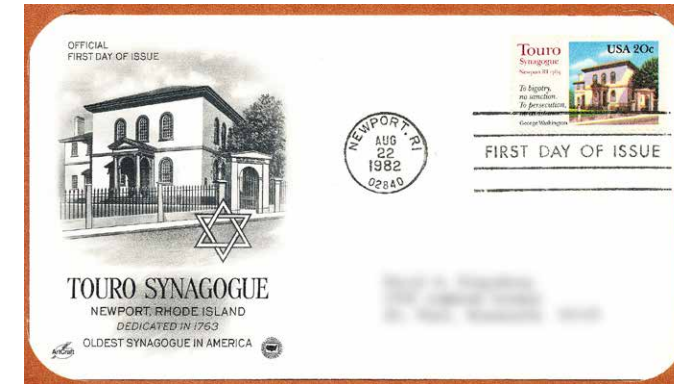
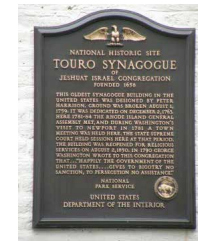
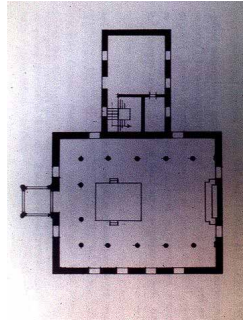
## Synagogue Het Tet Yud

When I learned to recite the Hebrew alphabet, the middle three letters Het Tet Yud were spoken in a rush, like elenenohpee in the English alphabet. Het signifies life, Tet, the good, and Yud, the hand. Their combinations are suggestive for architecture. They might comprise a series of 3 interrelated projects: Your Synagogue, My Synagogue, Our Synagogue. Yours is what “you” want, what the world expects, the Tradition! of *Fiddler on the Roof*. Mine will be what “I” want, the place I feel most in tune with this Holy Universe. Ours may become a synthesis and commentary on the other two.

It is easy to believe in a benevolent Divinity when all is right with the world. In Super Bowl post game shows, we often hear praise of The Lord from winning team members. I wonder how that same Lord fares in the losers’ locker room. I have never felt more blessed, where the world around me so completely supported my inner aspirations, as I did during a 2009 residency at The MacDowell Colony. “Thank god I’m *here*” was my first thought every time I awoke in Adams, my splendid and spacious studio at MacDowell, clearly the best fit for My Synagogue. So I carefully documented and modeled Adams in SketchUp 3D software. Photos of work on studio walls became equivalent surfaces in the digital model. In Adams my mind was both in focus and in flux. Deep study came in slow time, even stop time; work got done yet the clock did not change! Thoughts were flying-- and landing. Shadowed models pop off the surface of the page, yet also drop deeply into nested self-reference with their own ghostly interiors.

Walking to my studio one morning, I wondered what kind of concert hall would fit the works of composer Alvin Singleton, a fellow colonist whose music ranges from cerebral to sensuous, from concerto to discotheque. After a quick freehand sketch, I translated that passing whim into full-fledged architecture in less than a day. The classic central plan sustains concert stage and seating across a dance hall with 3 tiers of nightclub *boites* facing a wide dance ramp. Balcony access resolves the syncopation of the 8 and 12 foot vertical intervals. Corners contain fire stairs and services. For one person to go from rough sketch to finished design in a single day is an astonishing development in the history of architecture. While long experience facilitated rapid decisions, digital technology resolved the Idea to high precision and clarity. But what truly brought the work to quick fruition was the sacred magical spacetime of MacDowell itself.

## TOURO SYNAGOGUE JBF PLUS PIX HERE



### George Washington's Letter to the Hebrew Congregation in Newport, Rhode Island

Gentlemen:

While I received with much satisfaction your address replete with expressions of esteem, I rejoice in the opportunity of assuring you that I shall always retain grateful remembrance of the cordial welcome I experienced on my visit to Newport from all classes of citizens.

The reflection on the days of difficulty and danger which are past is rendered the more sweet from a consciousness that they are succeeded by days of uncommon prosperity and security.

If we have wisdom to make the best use of the advantages with which we are now favored, we cannot fail, under the just administration of a good government, to become a great and happy people.

The citizens of the United States of America have a right to applaud themselves for having given to mankind examples of an enlarged and liberal policy—a policy worthy of imitation. All possess alike liberty of conscience and immunities of citizenship.

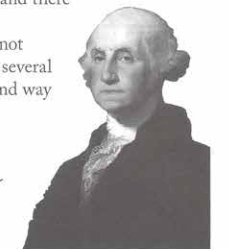
It is now no more that toleration is spoken of as if it were the indulgence of one class of people that another enjoyed the exercise of their inherent natural rights, for, happily, the Government of the United States, which gives to bigotry no sanction, to persecution no assistance, requires only that they who live under its protection should demean themselves as good citizens in giving it on all occasions their effectual support.

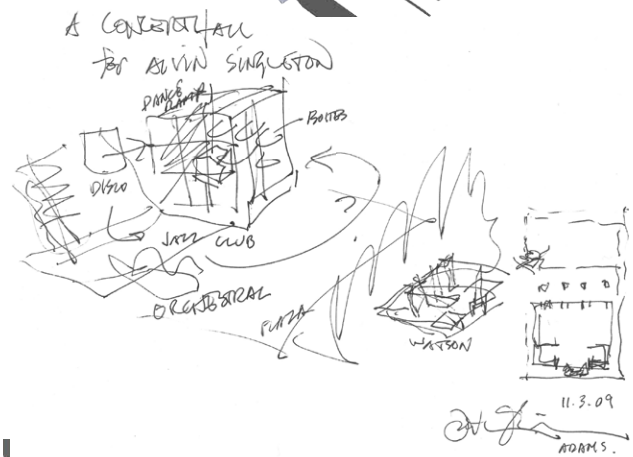
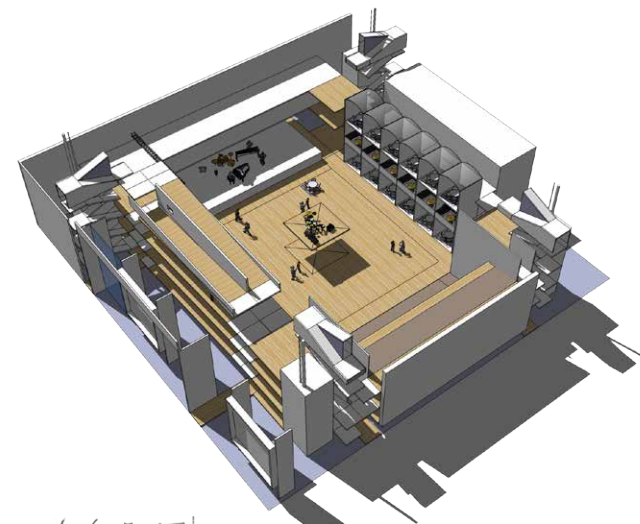
It would be inconsistent with the frankness of my character not to avow that I am pleased with your favorable opinion of my administration and fervent wishes for my felicity.

May the children of the stock of Abraham who dwell in this land continue to merit and enjoy the good will of the other inhabitants—while every one shall sit in safety under his own vine and fig tree and there shall be none to make him afraid.

May the father of all mercies scatter light, and make us all in our several vocations useful here, and in His own due time and way everlastingly happy.

*George Washington*





## Synagogue Het Tet Yud

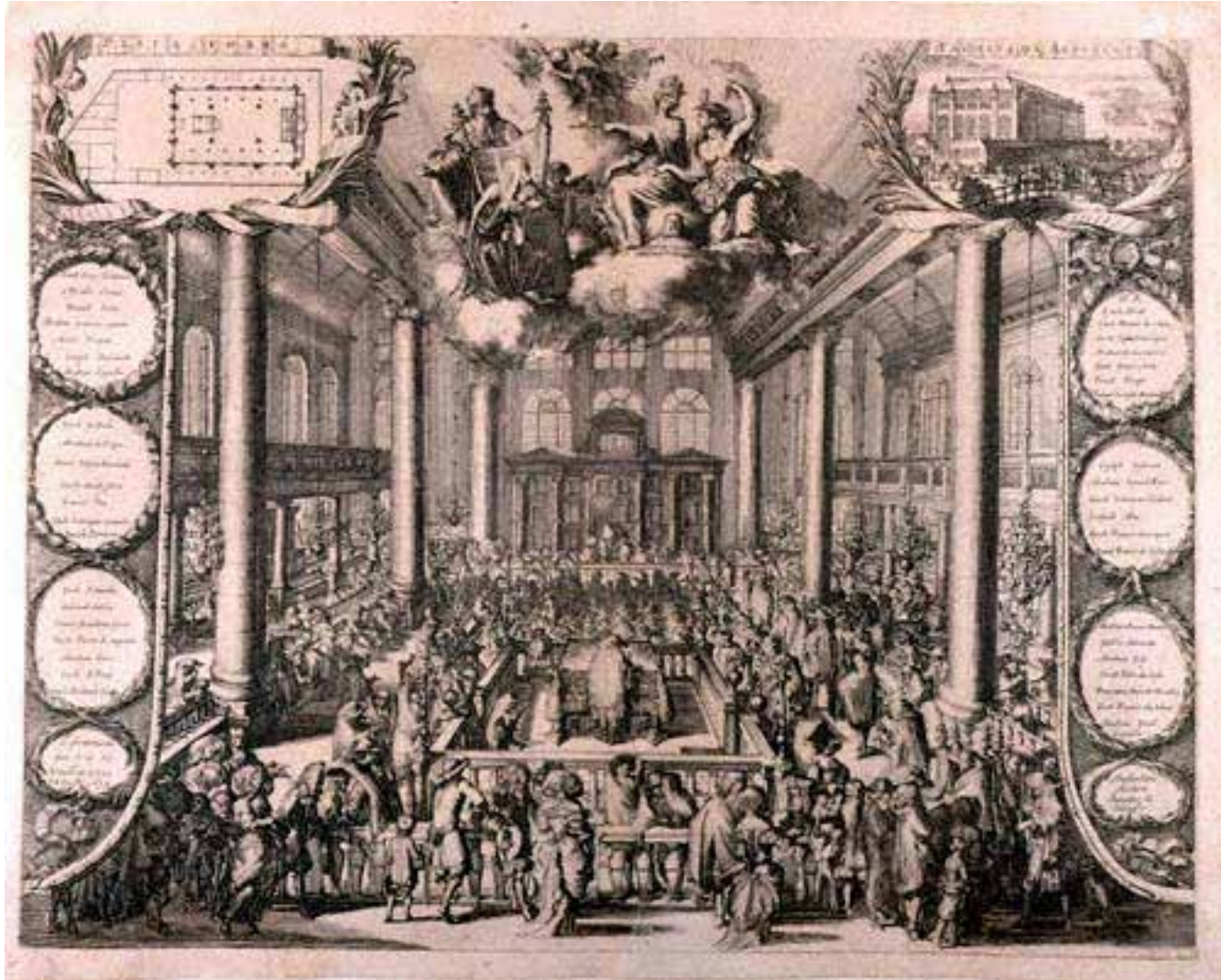
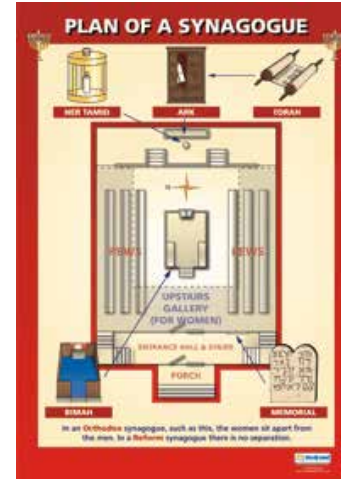
When I learned to recite the Hebrew alphabet, the next three letters Het Tet Yud were spoken in a rush, like elemehpee in the English alphabet. Het signifies life, Tet, the good, and Yud, the hand. Their combinations are suggestive for architecture. They might comprise a series of 3 interrelated projects: Your Synagogue, My Synagogue, Our Synagogue. Yours is what “you” want, what the world expects, the Tradition! of Fiddler on the Roof. Mine will be what “I” want, the place I feel most in tune with this Holy Universe. Ours may become a synthesis and commentary on the other two.

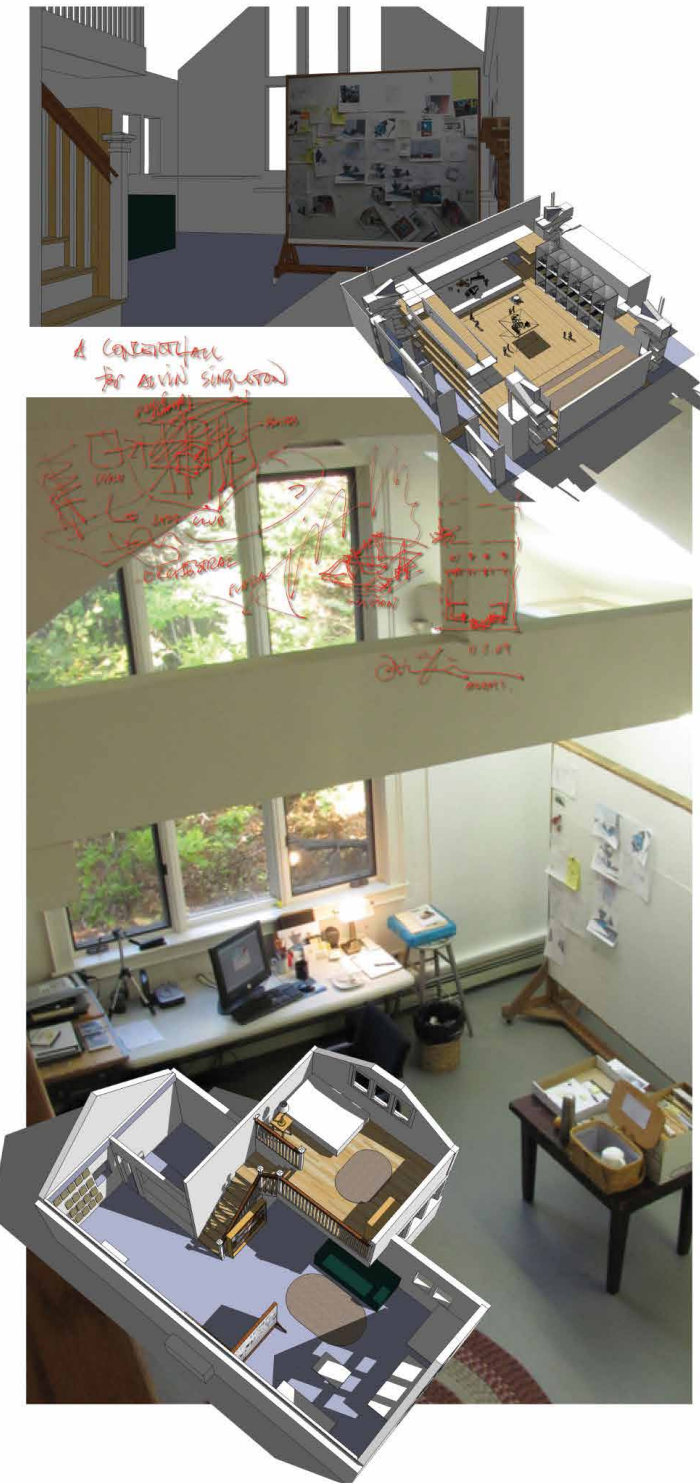
It is easy to believe in a benevolent Divinity when all is right with the world. In Super-Bowl post game shows, we often hear praise of The Lord from winning team members. I wonder how that same Lord fares in the losers’ locker room. I have never felt more blessed, where the world around me so completely supported my inner aspirations, as I did during a 2009 residency at The MacDowell Colony. Adams, my splendid and spacious studio there, was de facto the current best fit for My Synagogue. So I carefully documented and modeled it in SketchUp. Photos of work on studio walls became equivalent surfaces in the digital model. There my mind was both in focus and in flux. Deep study came in slow time, even stop time; work got done yet the clock did not change! On the facing page shadowed models pop off the page and picture plane, yet also drop deeply into nested self-reference with their own ghostly interiors.

Walking to my studio one morning, I wondered what kind of concert hall would fit the works of composer Alvin Singleton, a fellow colonist whose music ranges from cerebral to sensuous, from concerto to discotheque. After a quick freehand sketch, I translated that passing whim into full-fledged architecture in less than a day. The classic central plan sustains concert stage and seating across a dance hall with 3 tiers of nightclub *boites* facing a wide dance ramp. Balcony access resolves the syncopation of the 8 and 12 foot vertical intervals. Corners contain fire stairs and services. For one person to go from rough sketch to finished design in a day is an astonishing development in the history of architecture. While long experience facilitated rapid decisions, digital technology resolved the Idea to high precision and clarity. Just as in 1946, form emerges from solid darkness into timely light, or is it the other way around?



חטי





### Synagogue Het Tet Yud

When I learned to recite the Hebrew alphabet, the middle three letters Het Tet Yud were spoken in a rush, like elenenohpee in the English alphabet. Het signifies life, Tet, the good, and Yud, the hand. Their combinations are suggestive for architecture. They might comprise a series of 3 interrelated projects: Your Synagogue, My Synagogue, Our Synagogue. Yours is what “you” want, what the world expects, the Tradition! of *Fiddler on the Roof*. Mine will be what “I” want, the place I feel most in tune with this Holy Universe. Ours may become a synthesis and commentary on the other two.

It is easy to believe in a benevolent Divinity when all is right with the world. In Super Bowl post game shows, we often hear praise of The Lord from winning team members. I wonder how that same Lord fares in the losers’ locker room. I have never felt more blessed, where the world around me so completely supported my inner aspirations, as I did during a 2009 residency at The MacDowell Colony. “Thank god I’m *here*” was my first thought every time I awoke in Adams, my splendid and spacious studio at MacDowell, clearly the best fit for My Synagogue. So I carefully documented and modeled Adams in SketchUp 3D software. Photos of work on studio walls became equivalent surfaces in the digital model. In Adams my mind was both in focus and in flux. Deep study came in slow time, even stop time; work got done yet the clock did not change! Thoughts were flying-- and landing. Shadowed models pop off the surface of the page, yet also drop deeply into nested self-reference with their own ghostly interiors.

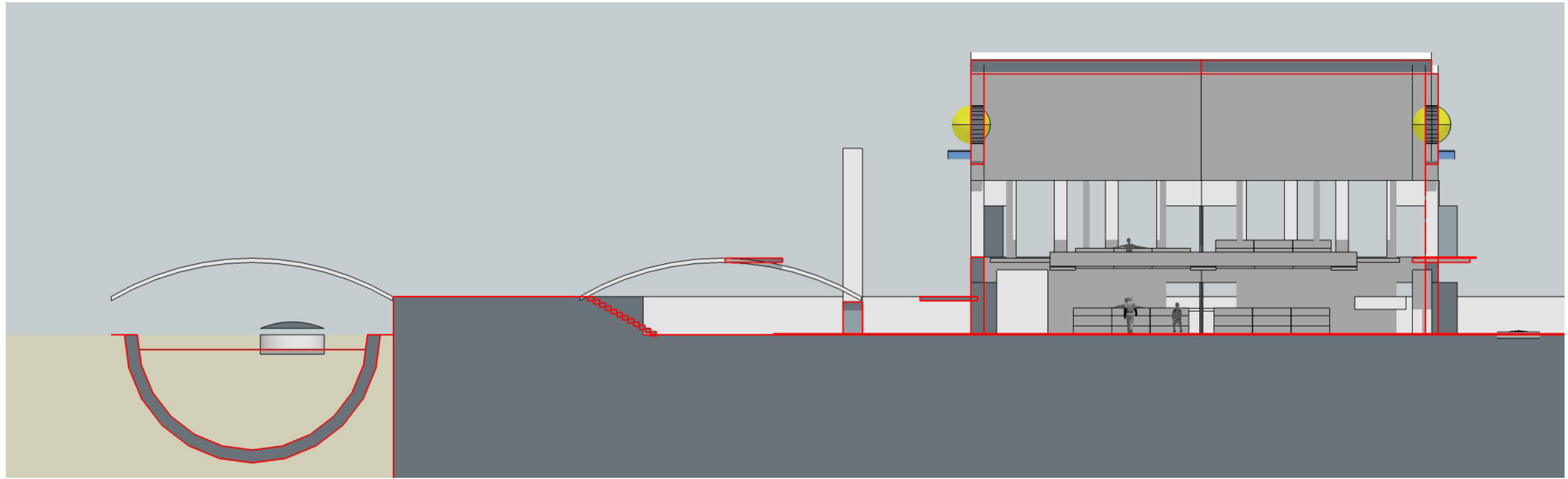
Walking to my studio one morning, I wondered what kind of concert hall would fit the works of composer Alvin Singleton, a fellow colonist whose music ranges from cerebral to sensuous, from concerto to discotheque. After a quick freehand sketch, I translated that passing whim into full-fledged architecture in less than a day. The classic central plan sustains concert stage and seating across a dance hall with 3 tiers of nightclub *boites* facing a wide dance ramp. Balcony access resolves the syncopation of the 8 and 12 foot vertical intervals. Corners contain fire stairs and services. For one person to go from rough sketch to finished design in a single day is an astonishing development in the history of architecture. While long experience facilitated rapid decisions, digital technology resolved the Idea to high precision and clarity. But what truly brought the work to quick fruition was the sacred magical spacetime of MacDowell itself.

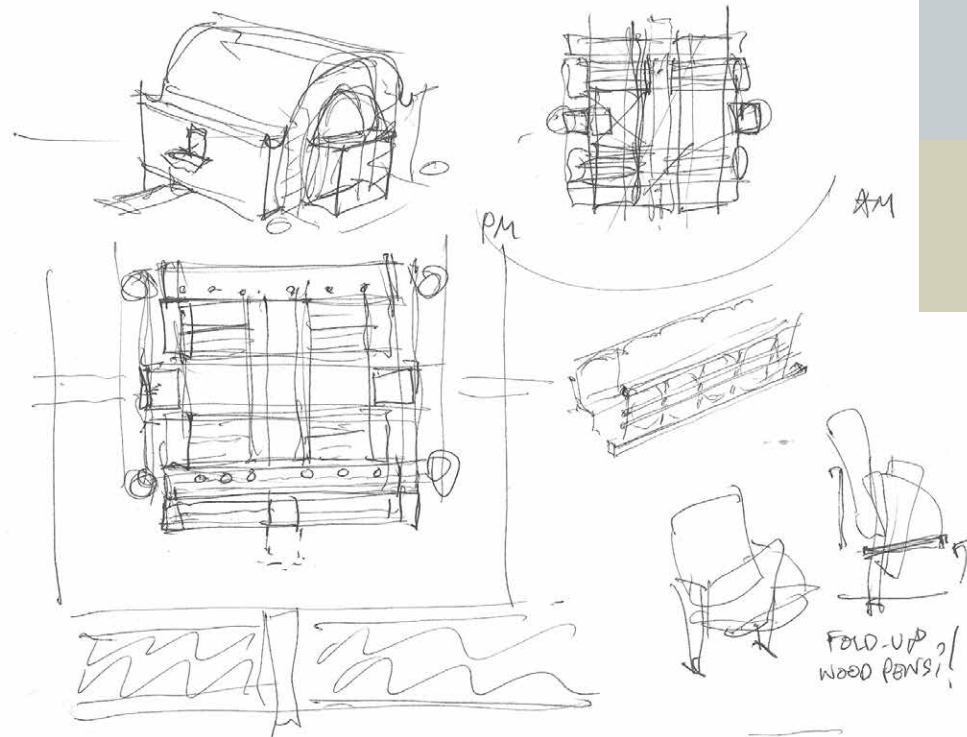


Photo Copyright Claire Rydell, 1997

The Portuguese Synagogue, 1675, considered the finest in Holland, is based on a model of Solomon's Temple and faces east, toward Jerusalem. The Ark is made of fine Brazilian wood.

**BUT THEN I LOOKED AROUND, FELT THAT AMSTERDAM WAS THE ORIGIN OF TOURO AND SO MANY OTHERS, IN A WAY, ????**  
**AND WAS MY ORIGIN ????**



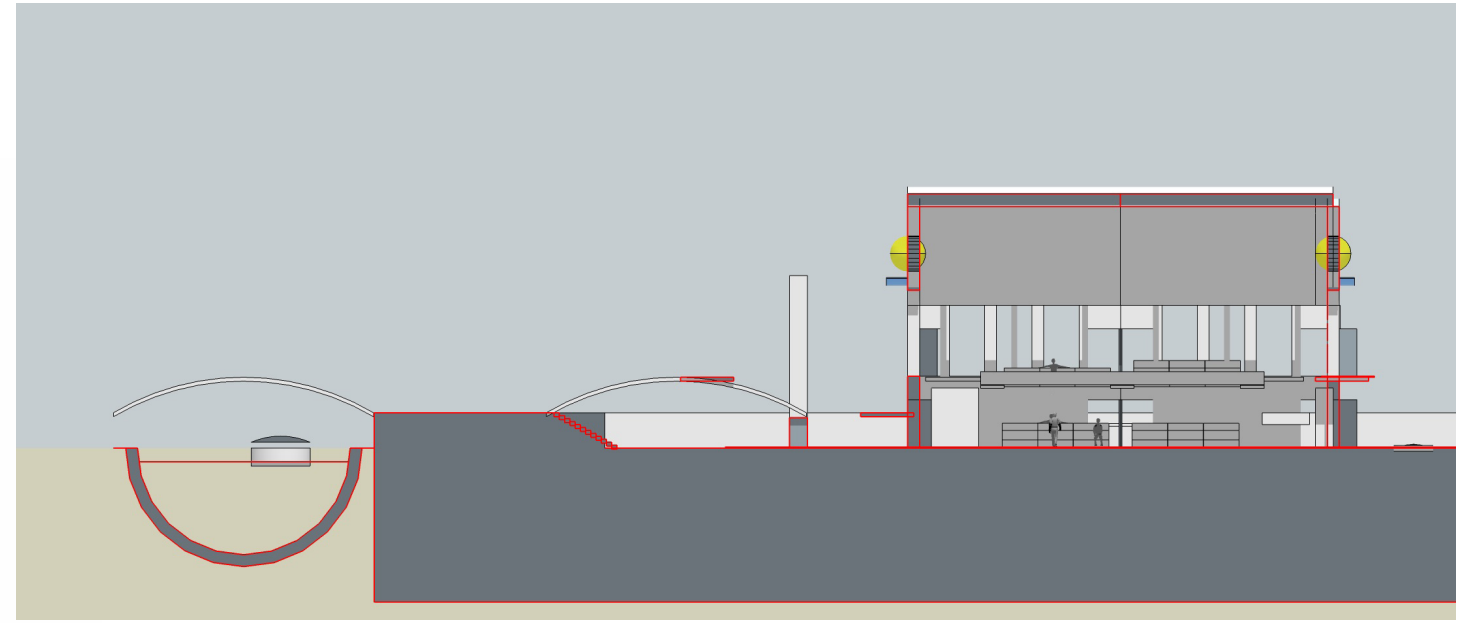


FINISH HST. GET ON WATER TO!

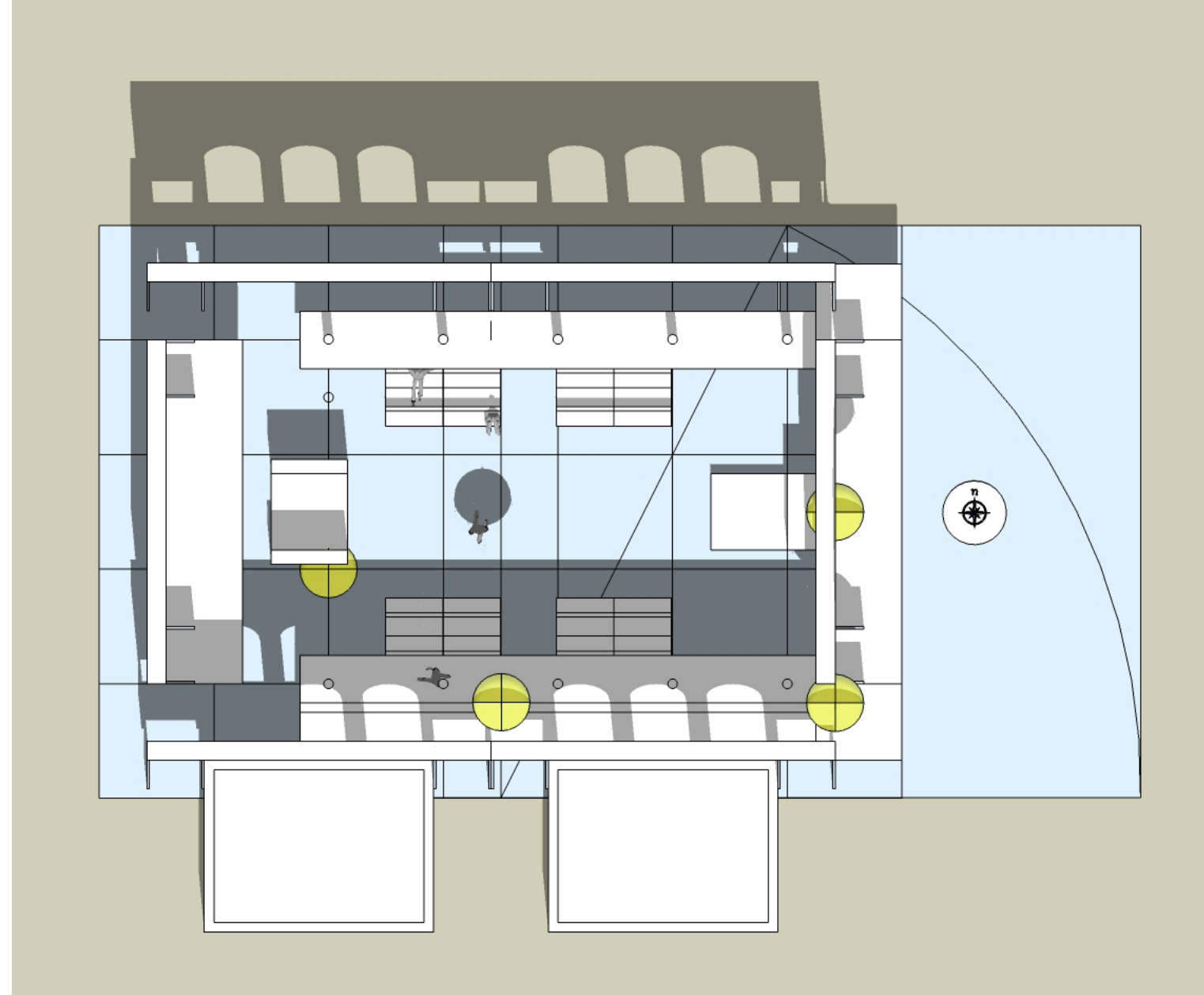
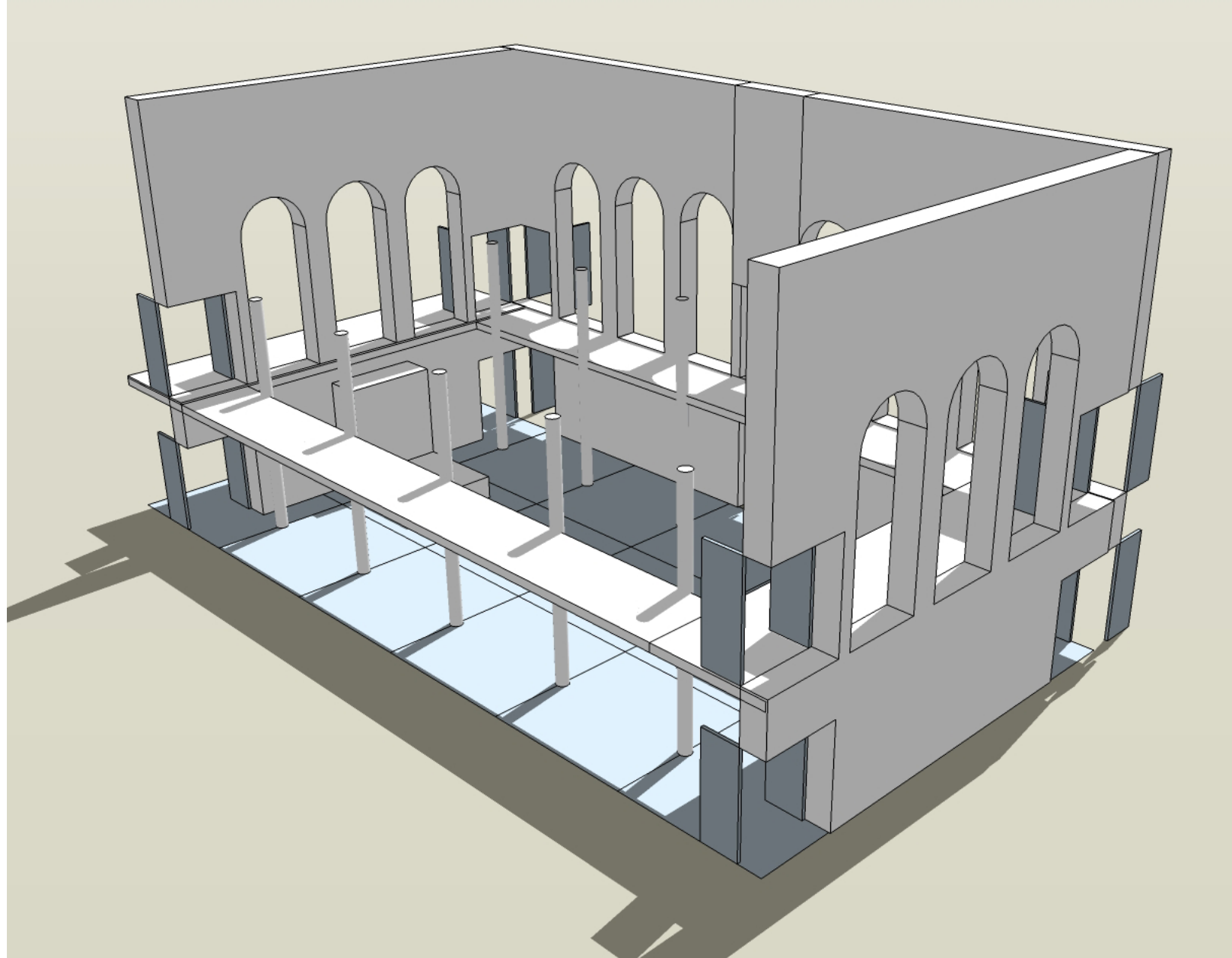
PILLARS -  
SMOKE  
PIPS.  
10 CS

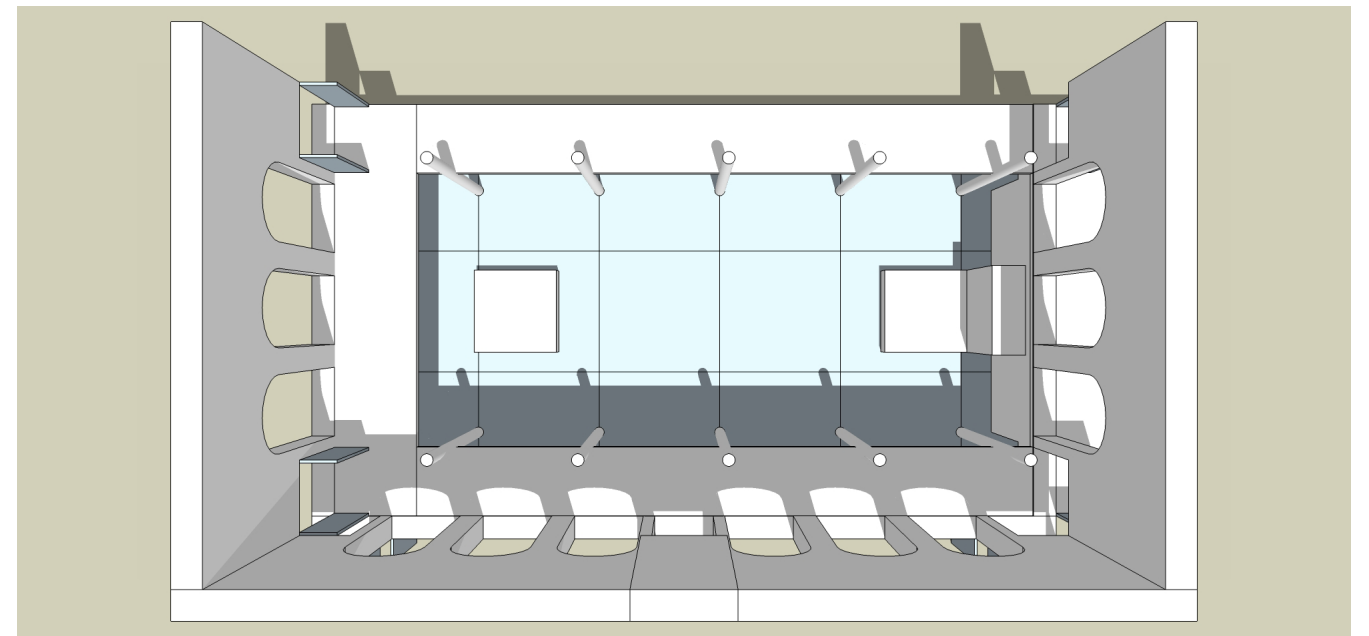
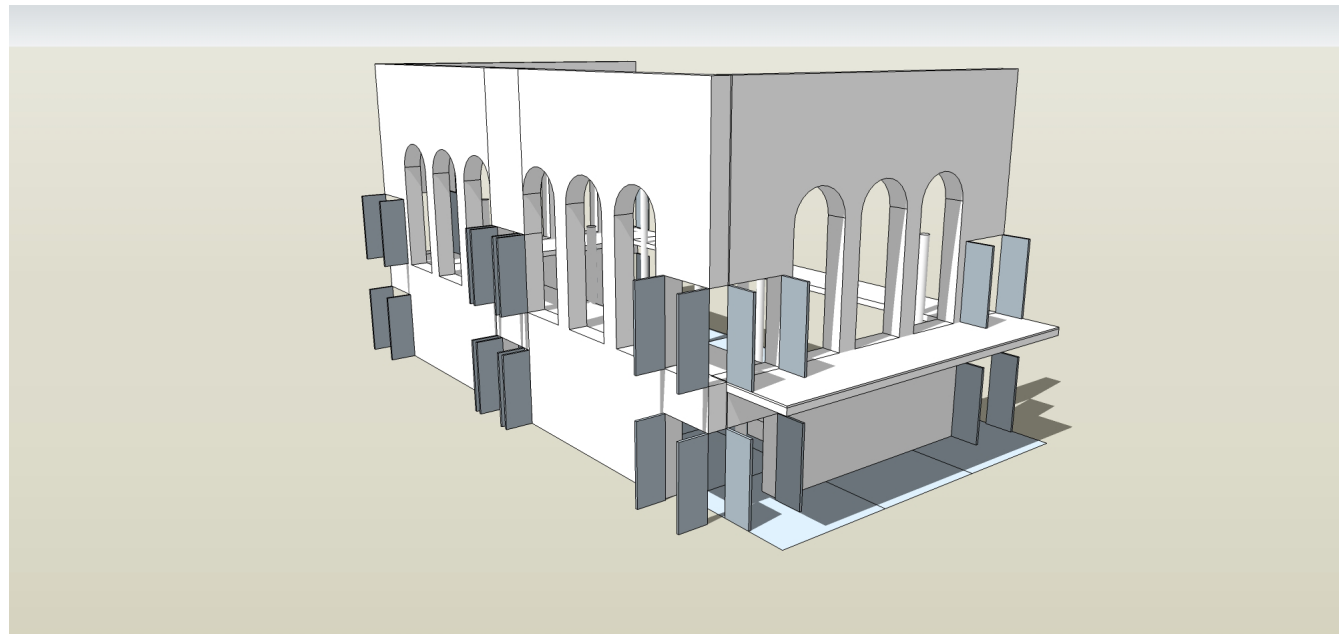
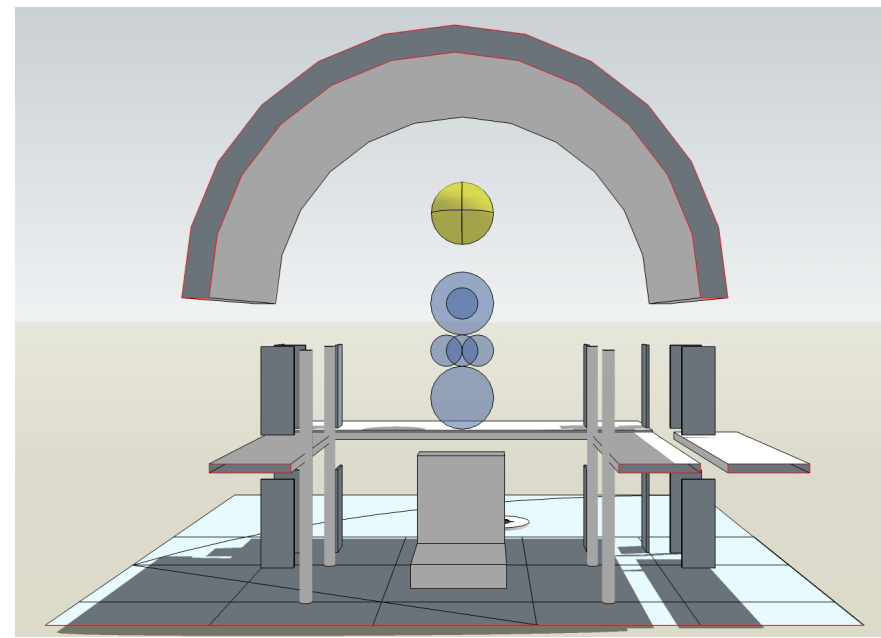
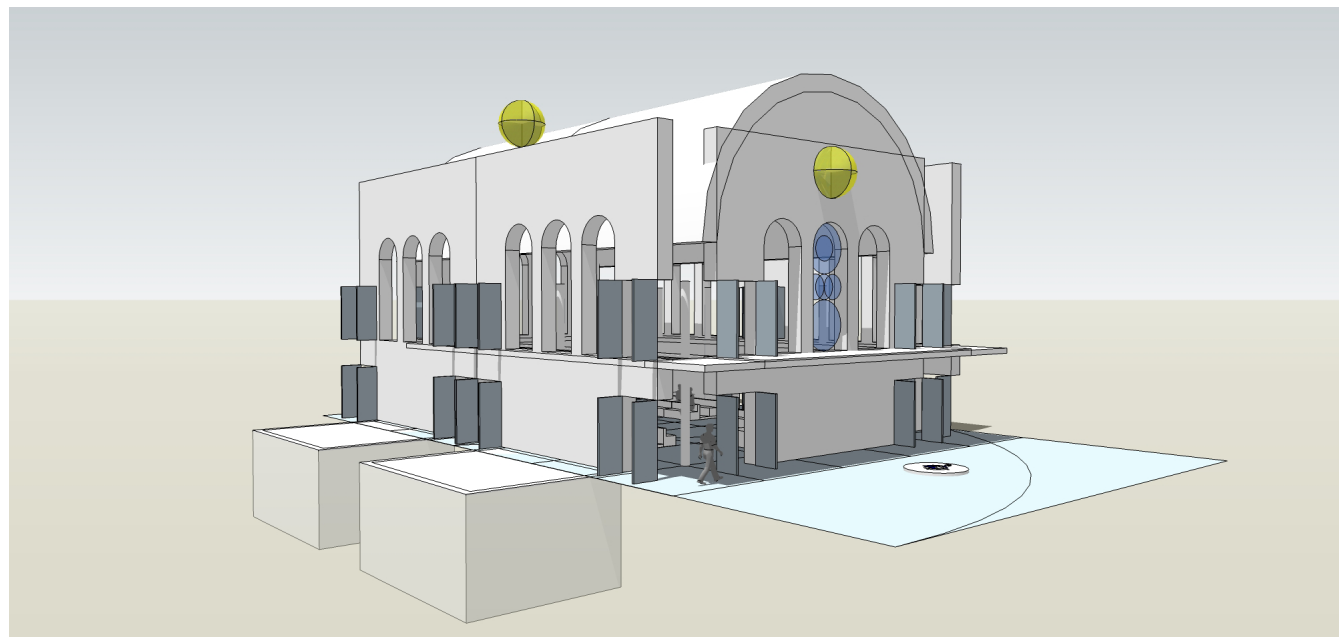
FOLD-UP  
WOOD PENS!

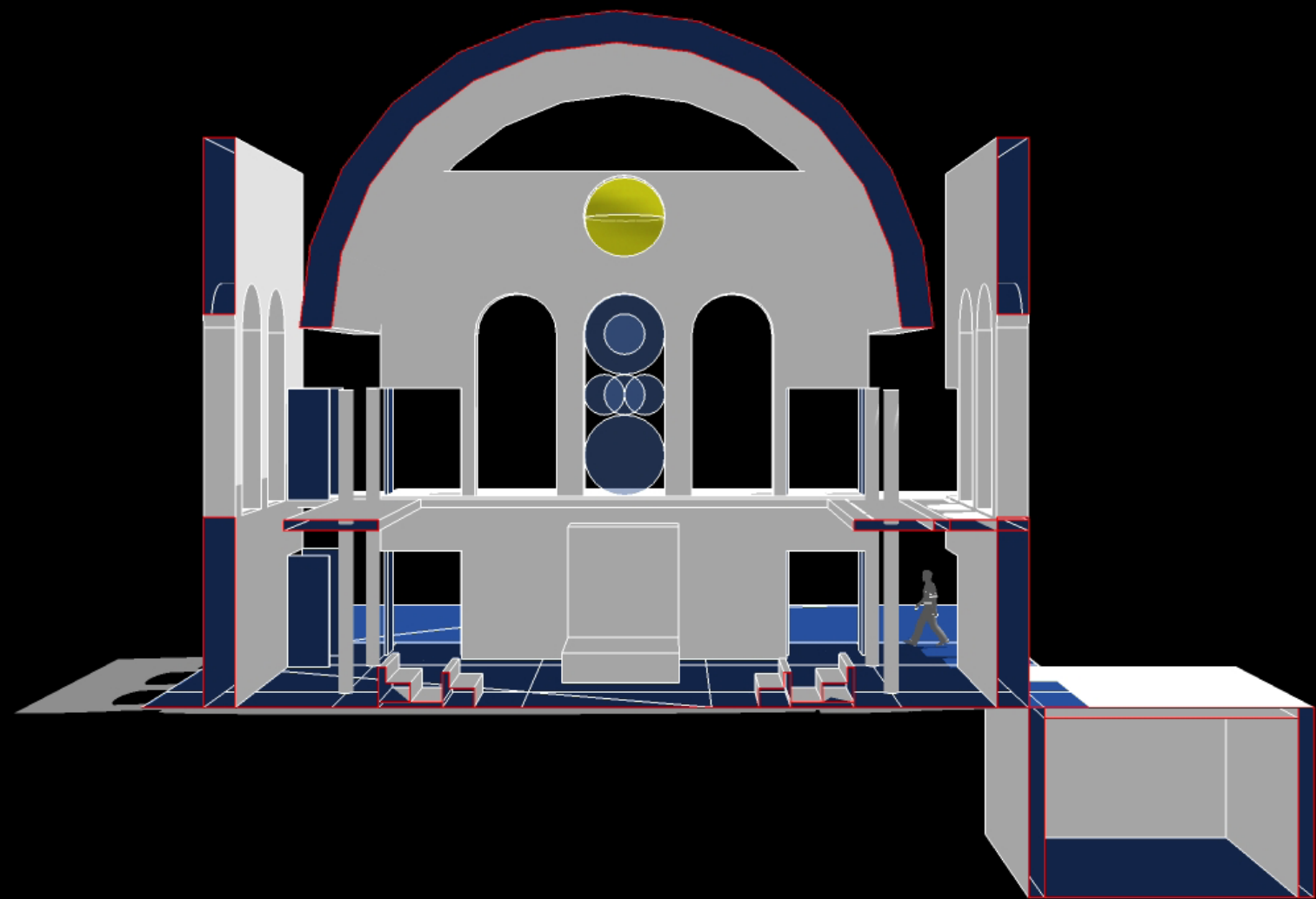
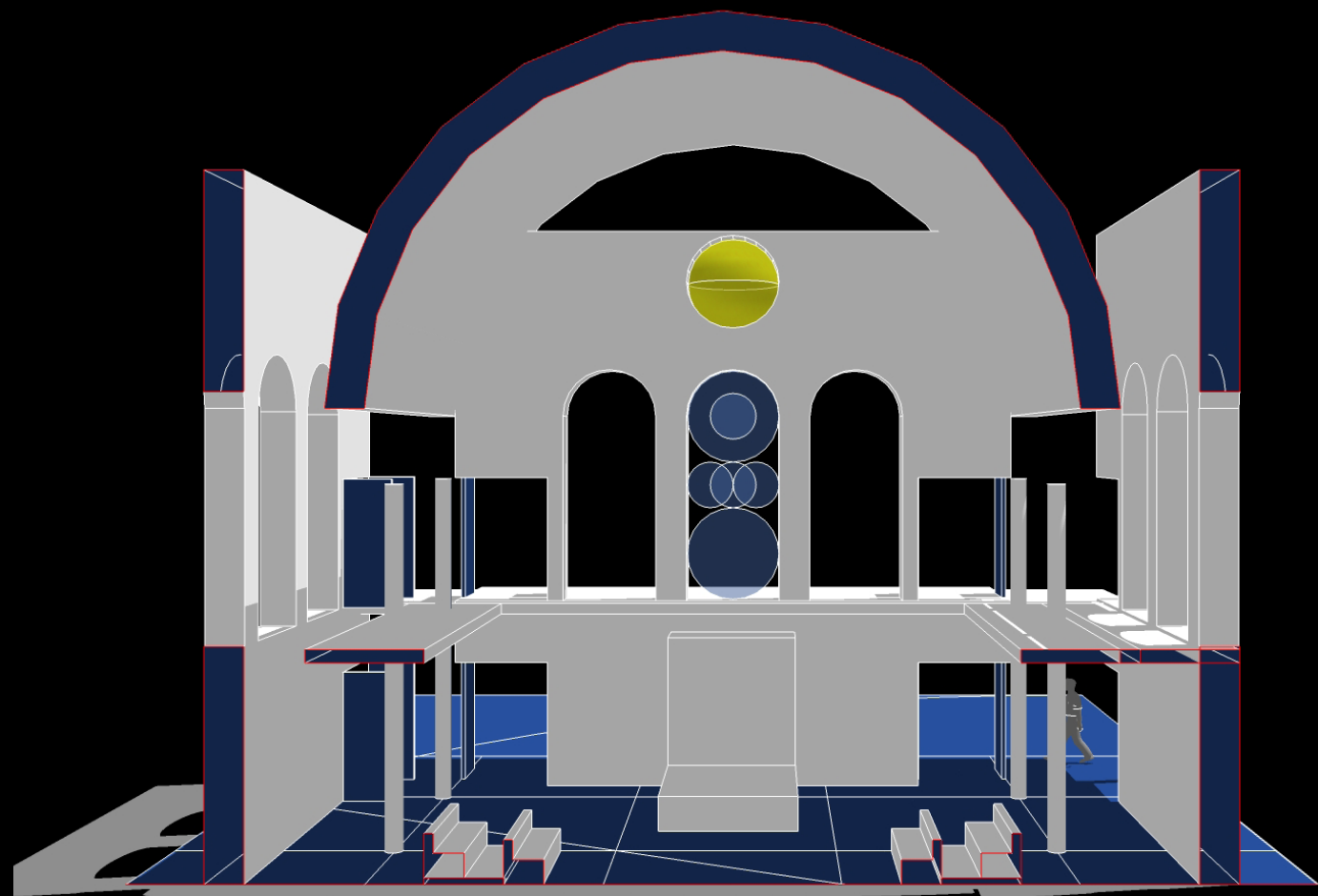
6.11.2012  
6.12.2012

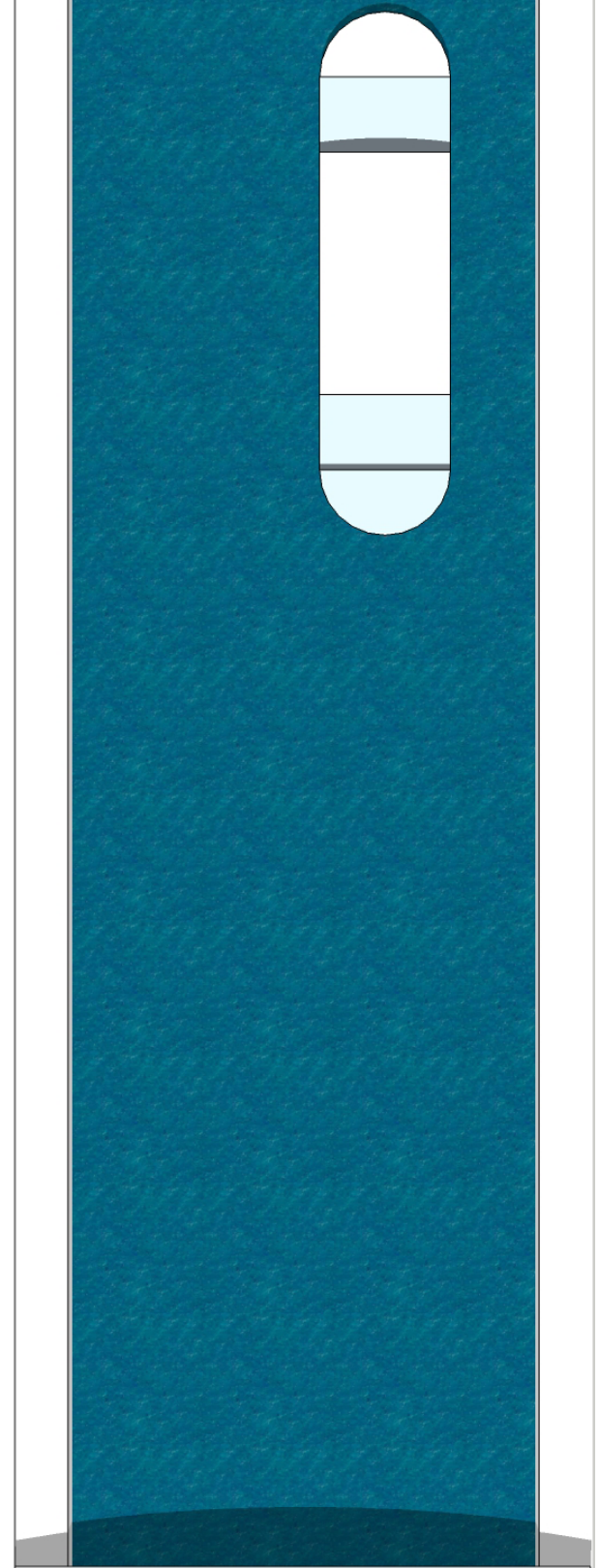
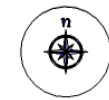
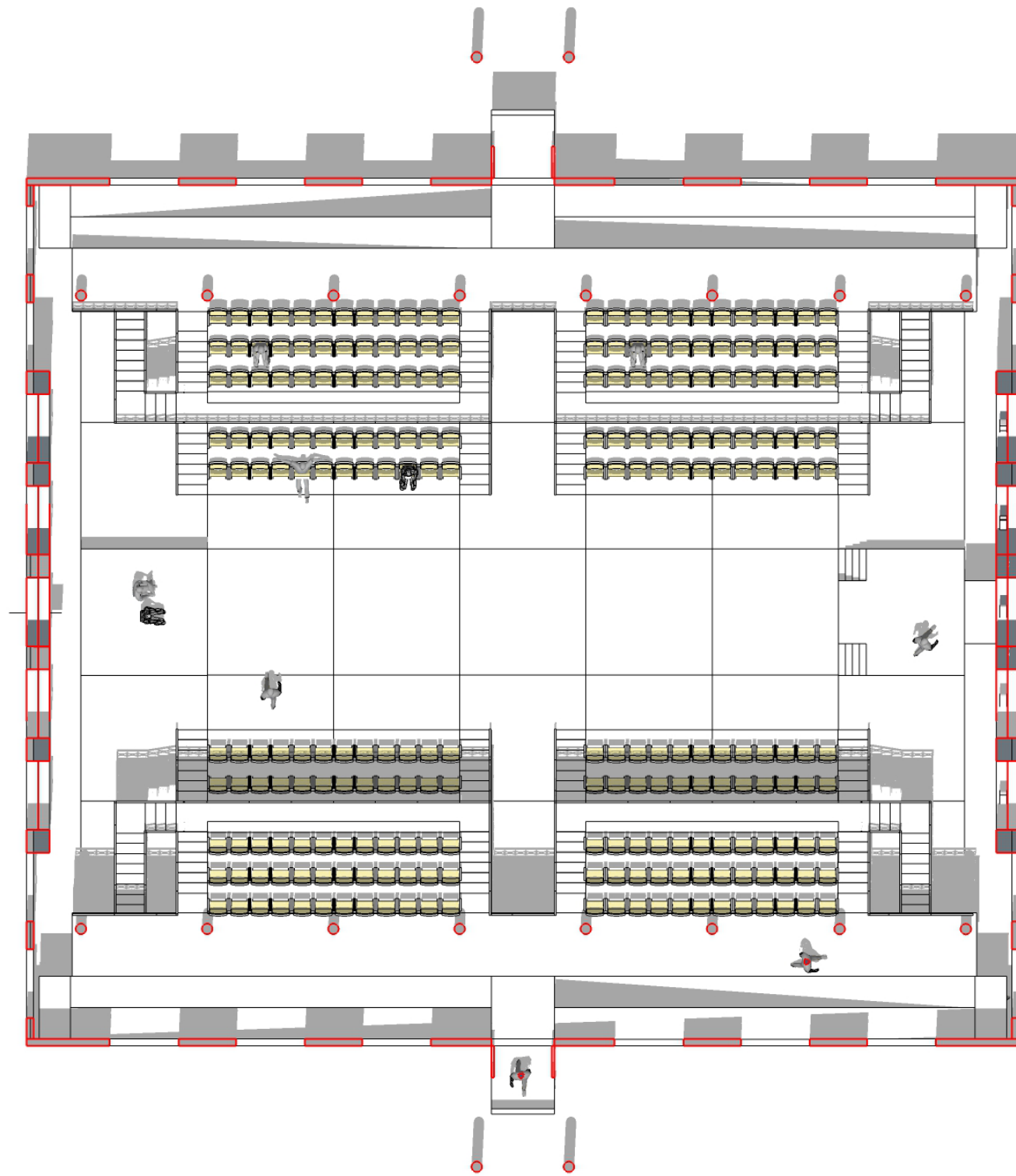


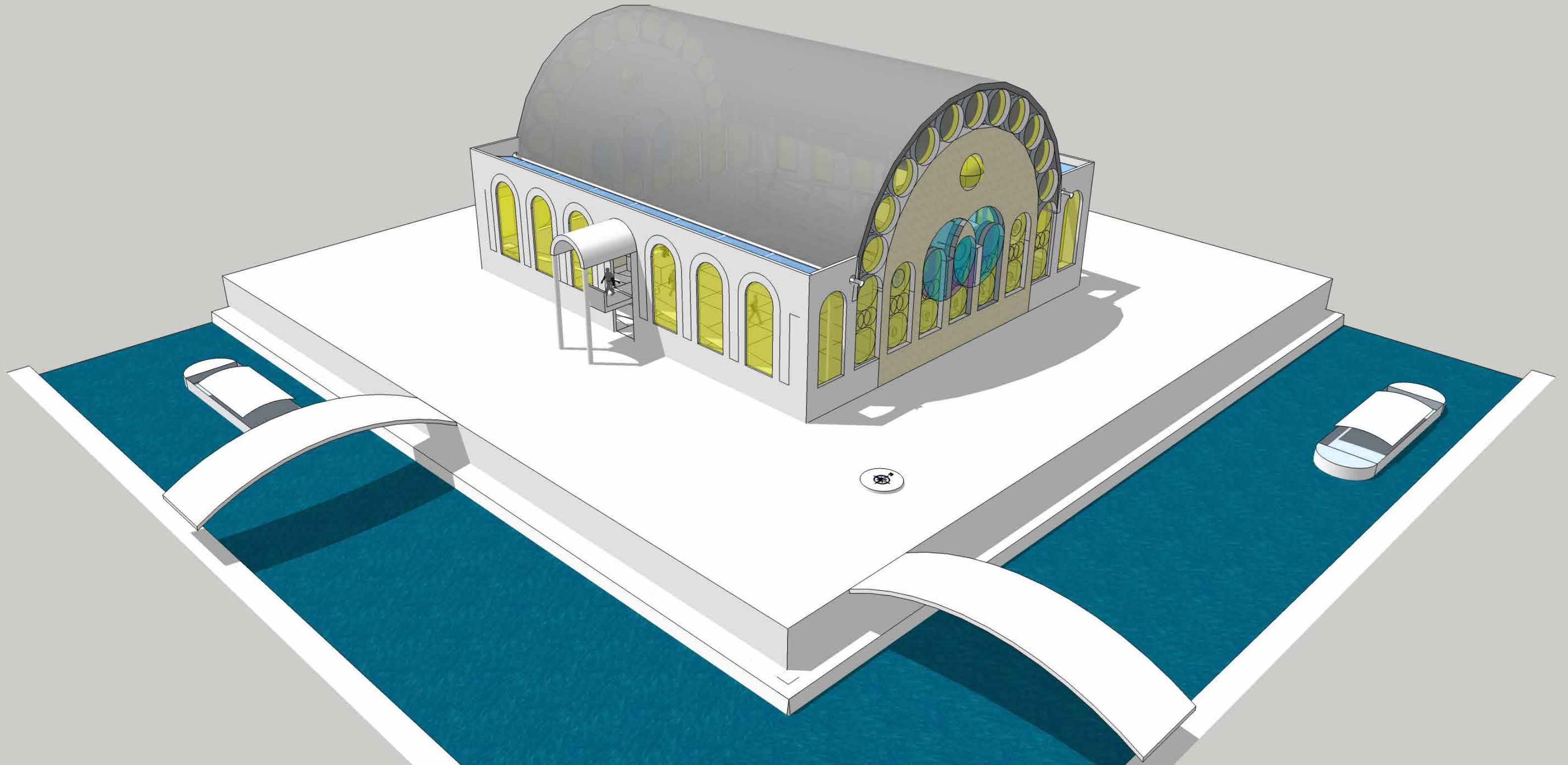


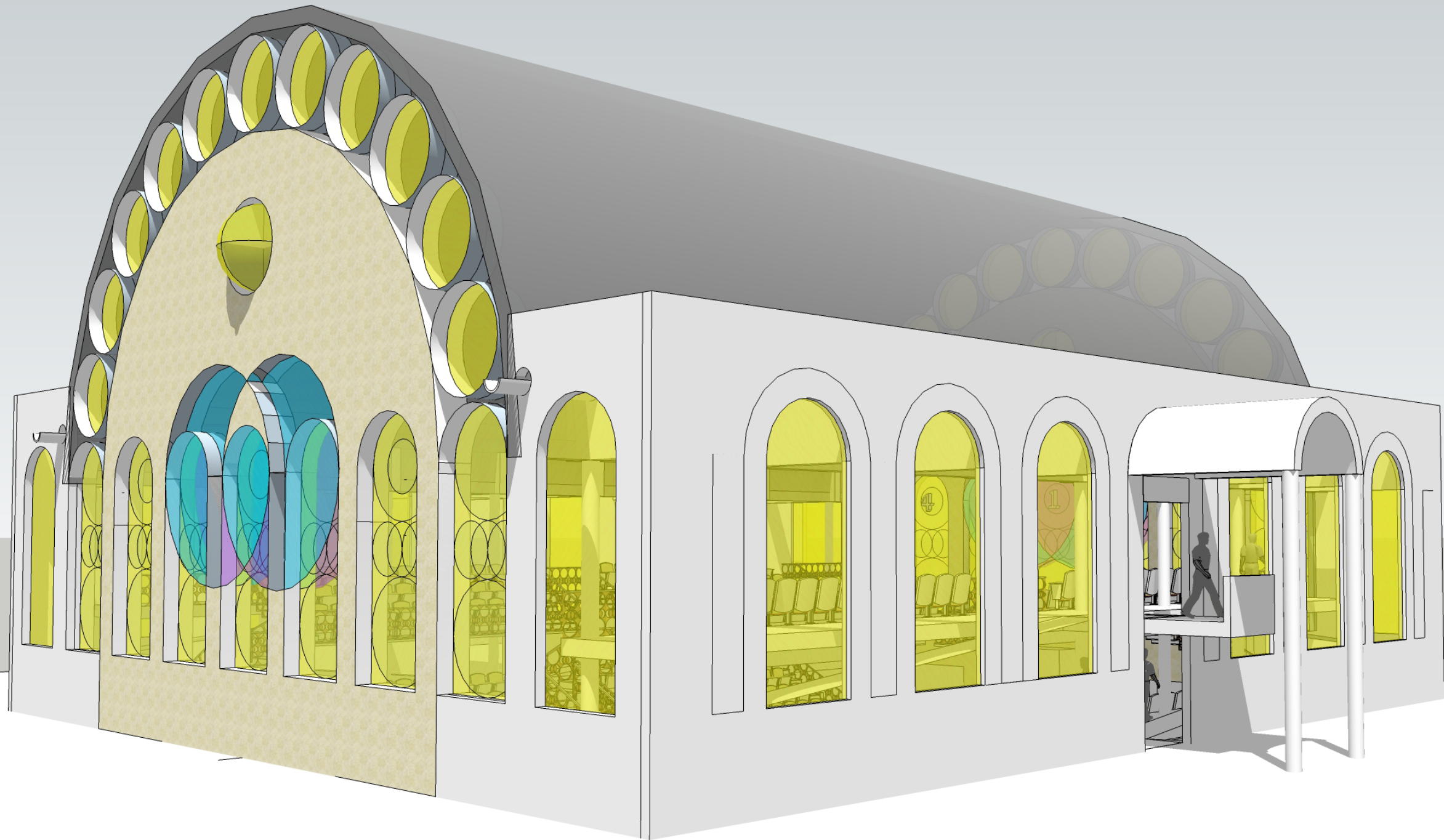


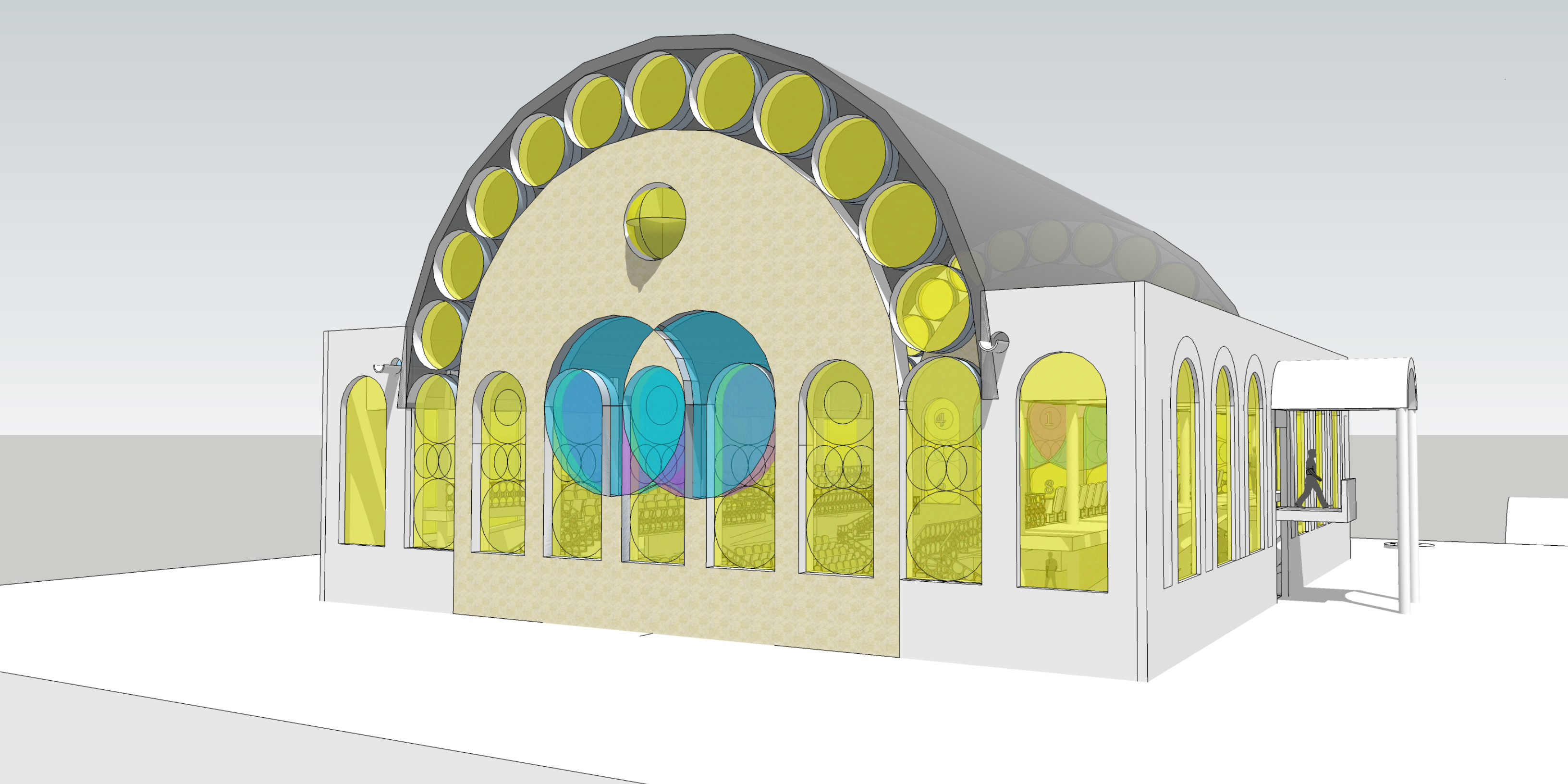


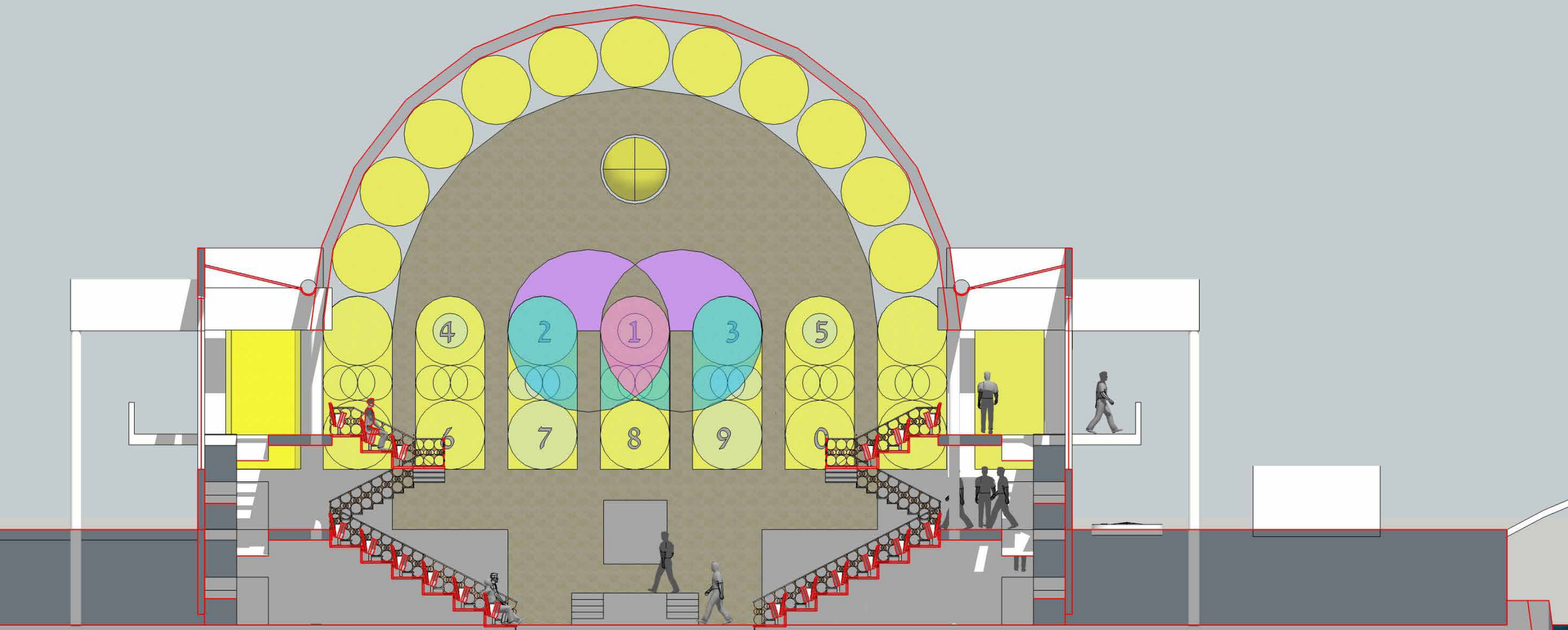




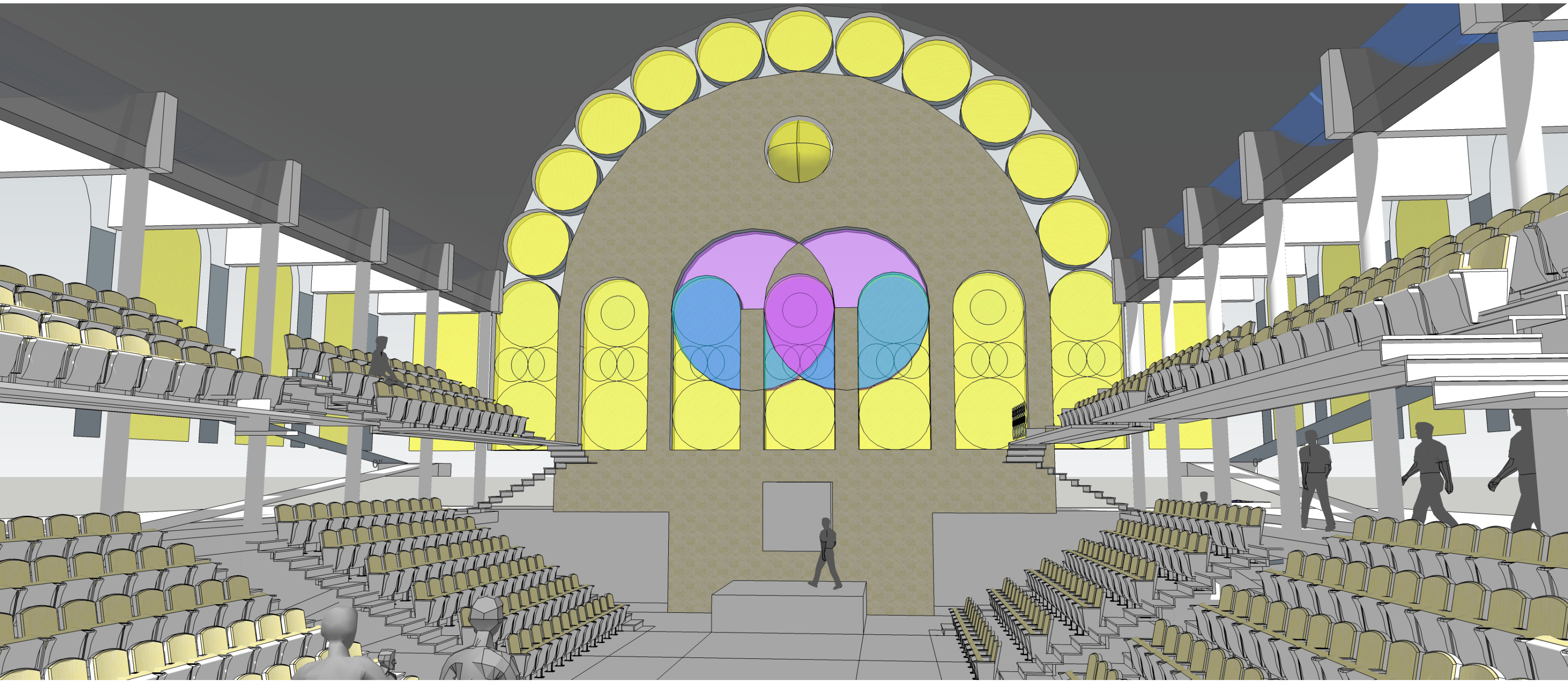




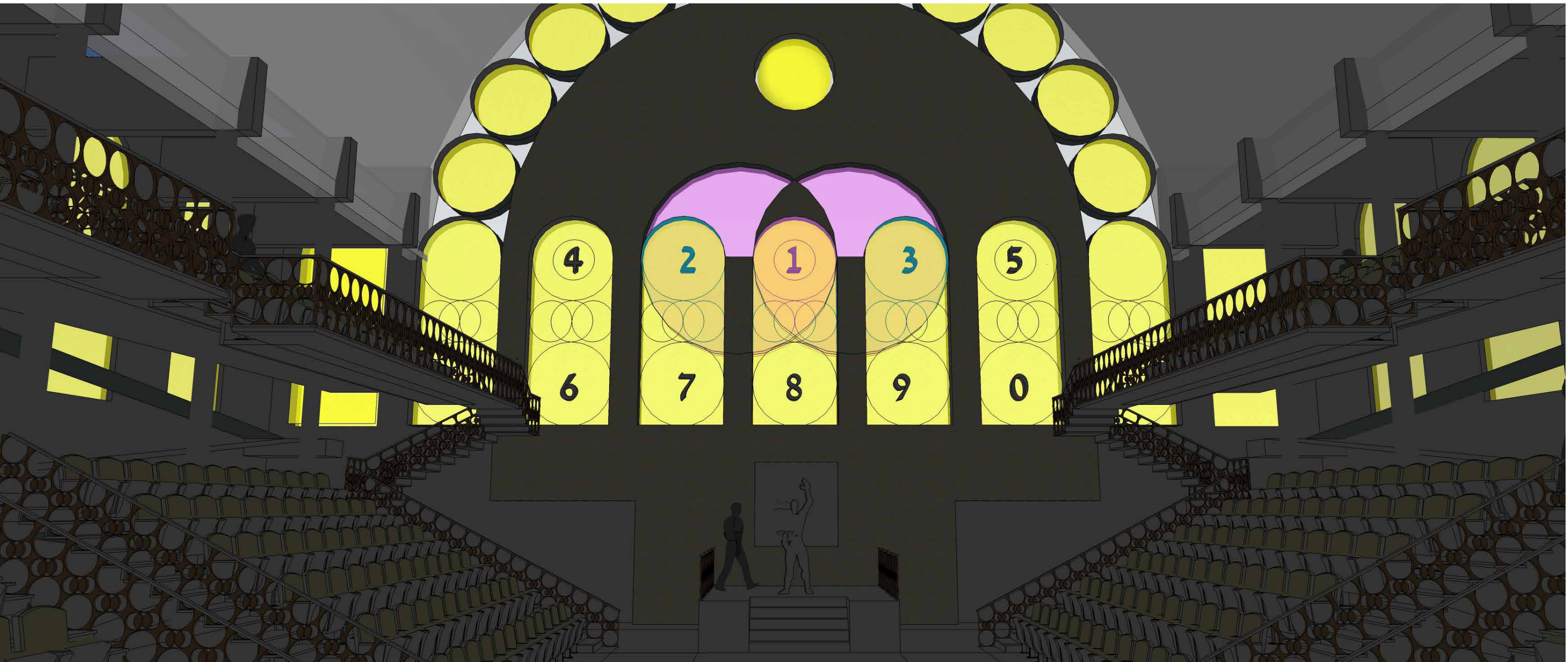


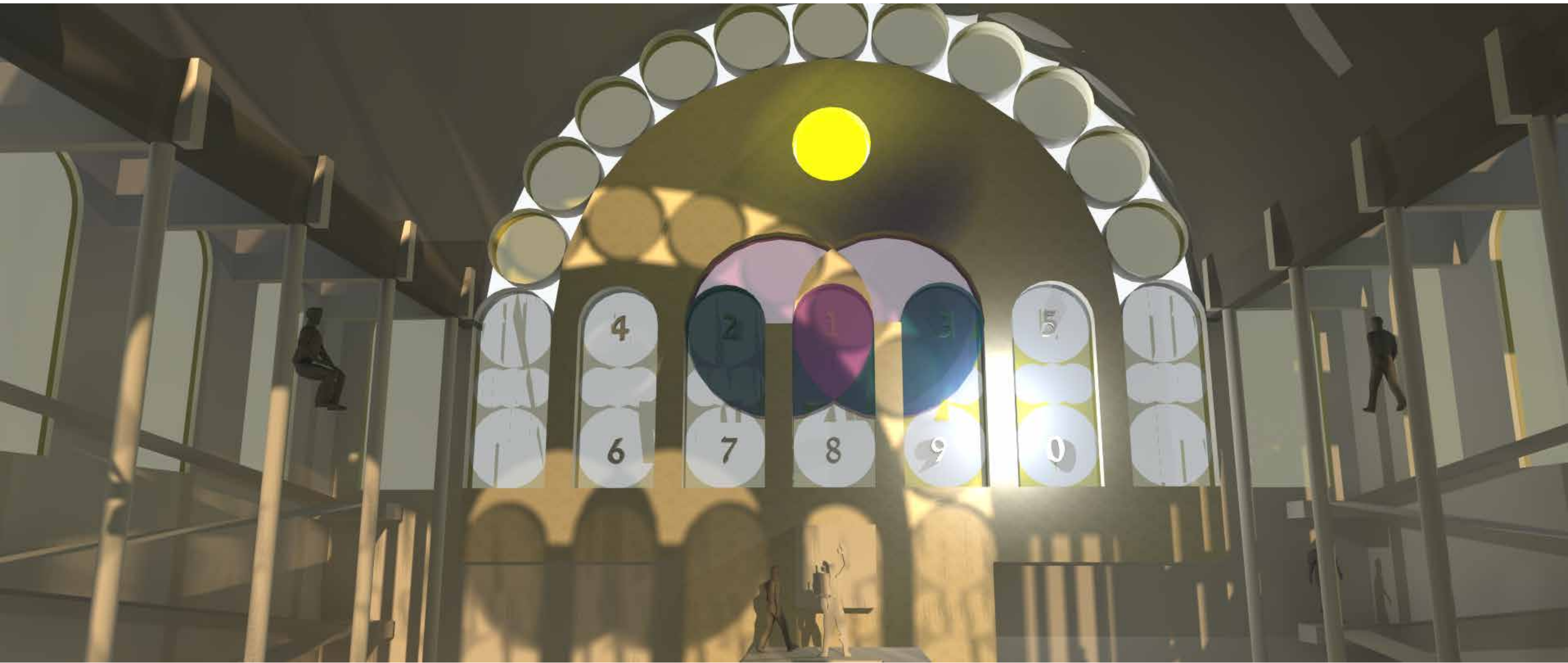




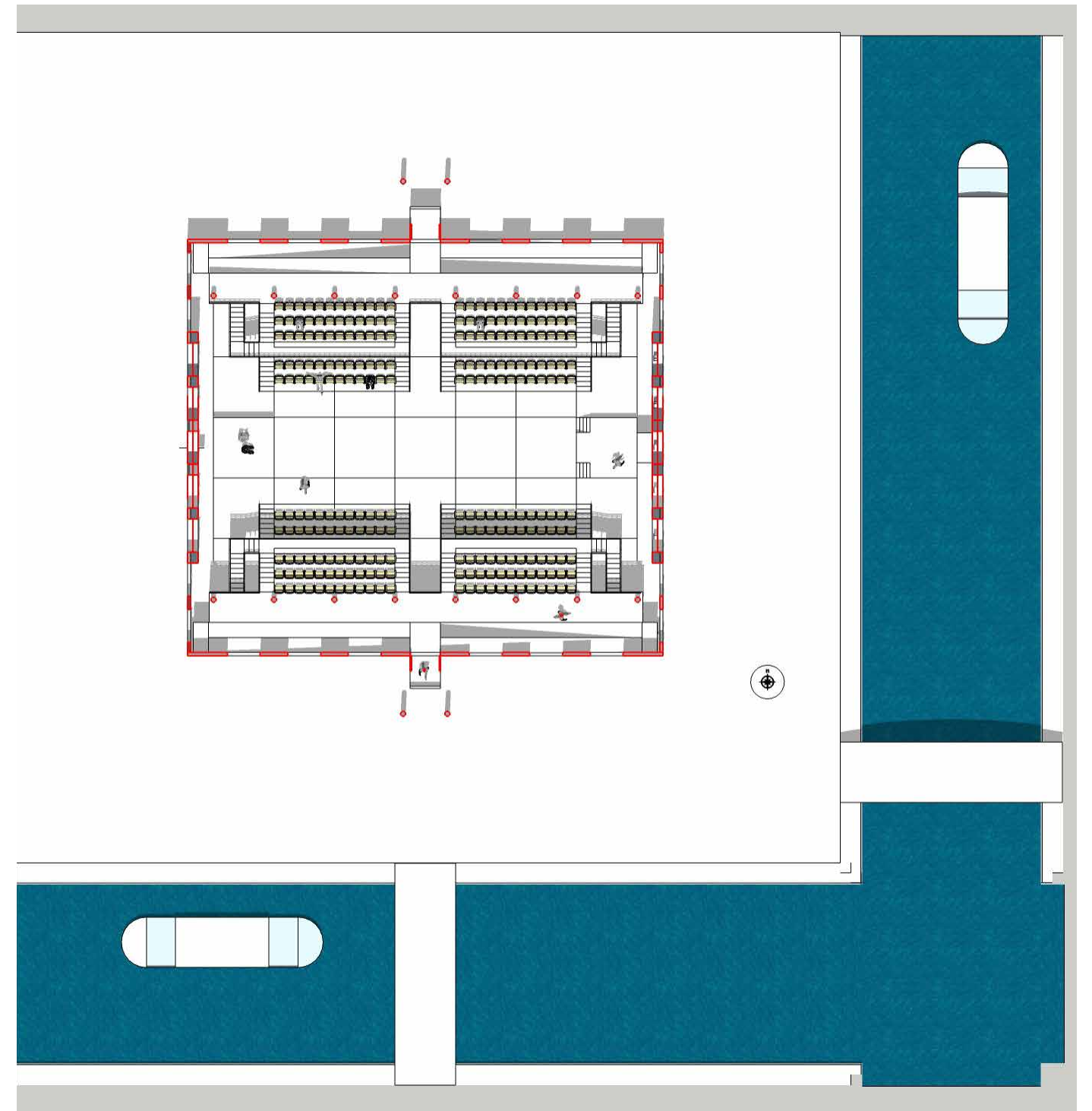














# SYNAGOGUE HET



ח

אבגדהו  
זחטיכל